

TEXTILE AIR DIFFUSERS - INSTRUCTIONS FOR MOUNTING

1 1D 1F see details A, B, C

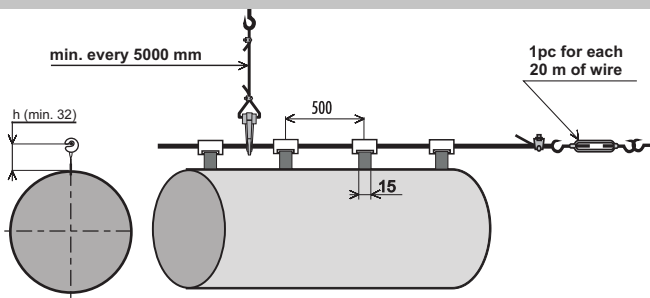

2 2D 2F see details A, B, C

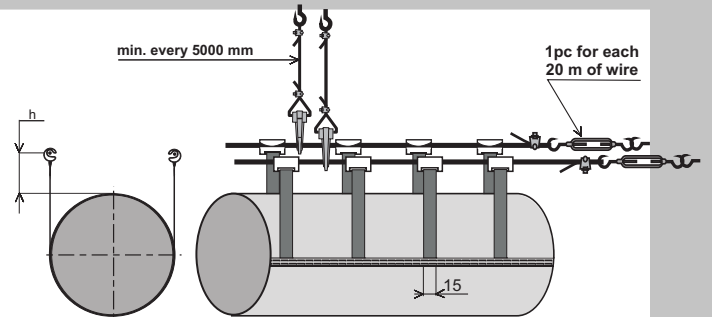

3 see details D, E

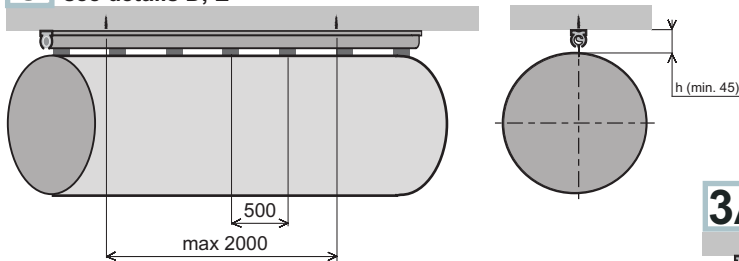

3A see details D, E

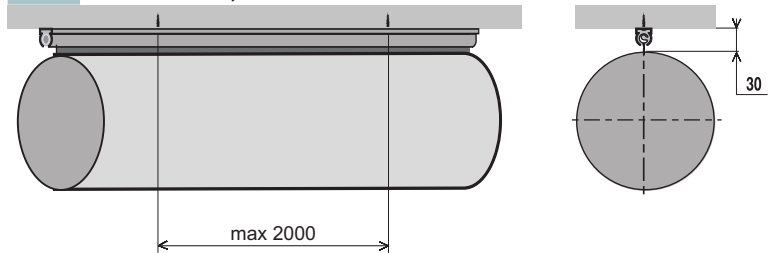

3B see detail H

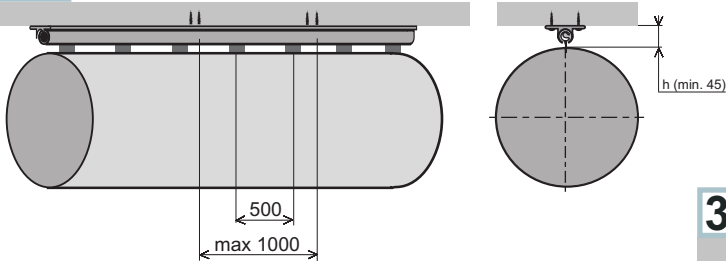

3AB see detail H

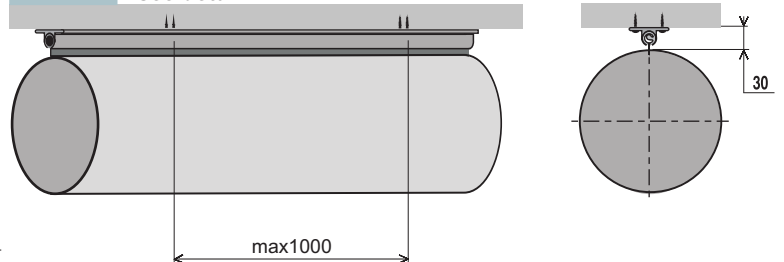

3AC see details J, E

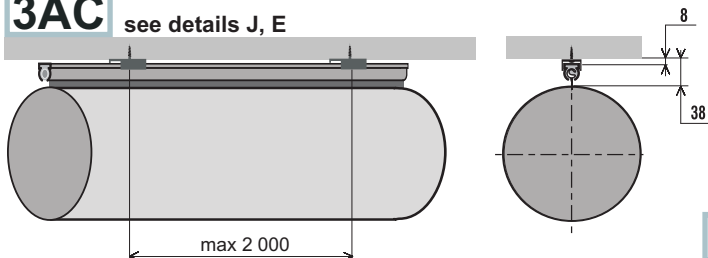

3C see details J, E

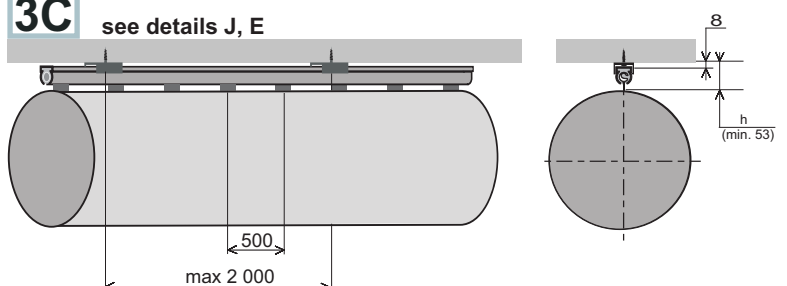

3G see details M,N

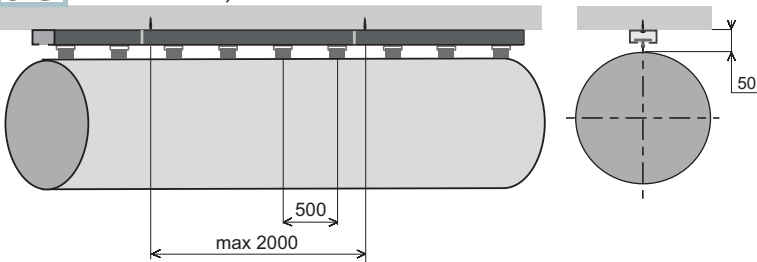

4 see details D, E

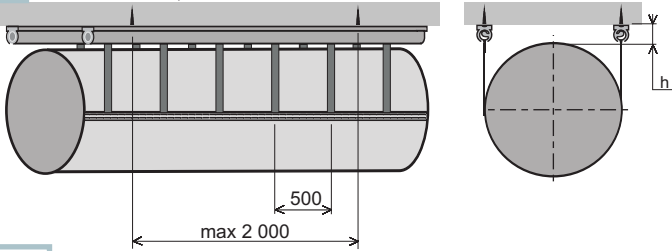

4B see detail H

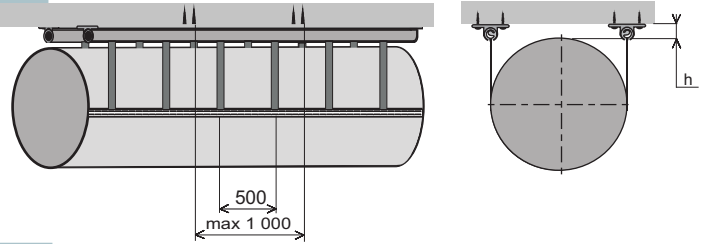

4C see details J, E

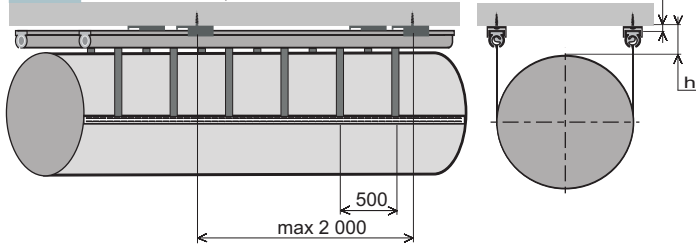

4G see details M, N

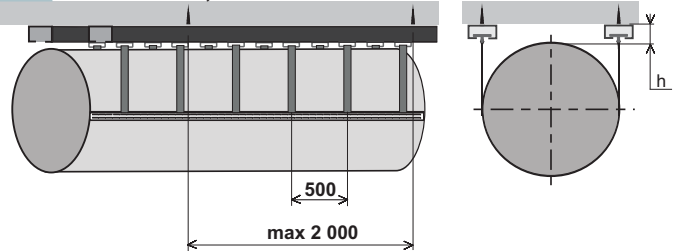

5 5D 5F see details G, E, F, K

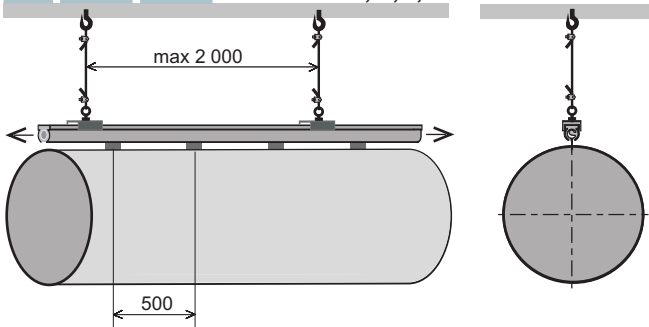

5E see details G, E, F

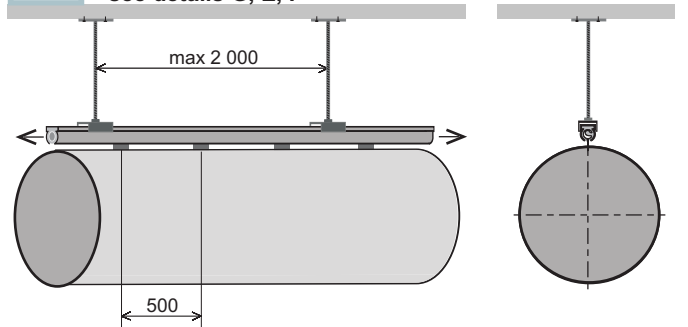

5A 5AD 5AF see details G, E, F, K

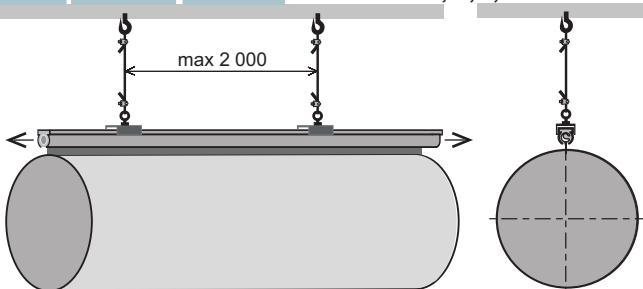

5AE see details G, E, F

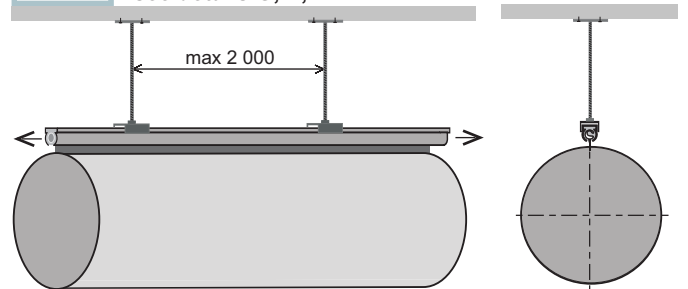

5EG see details F, M

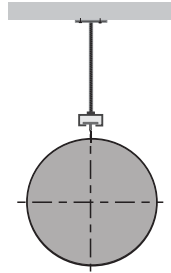
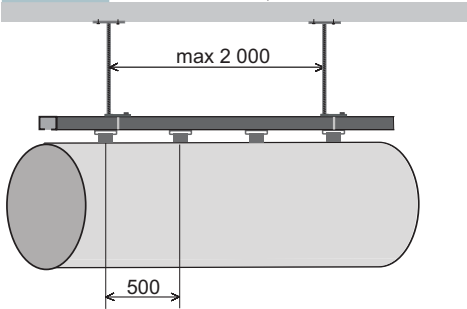

5G see details F, M

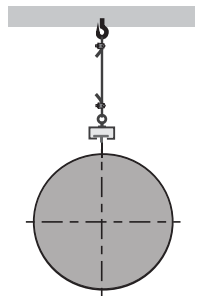
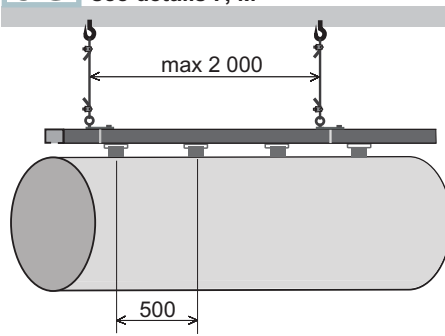

5I 5DI 5FI see details G, K, R

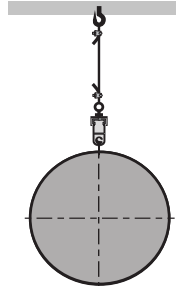
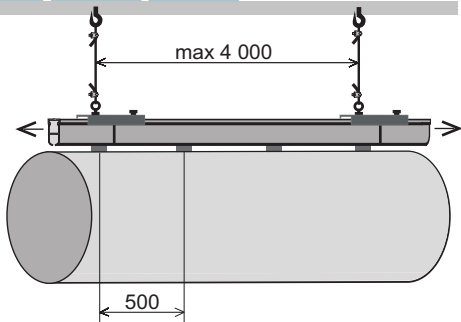

5AI 5ADI 5AFI see details G, K, R

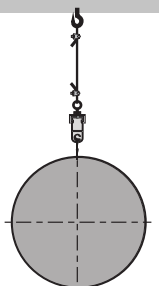
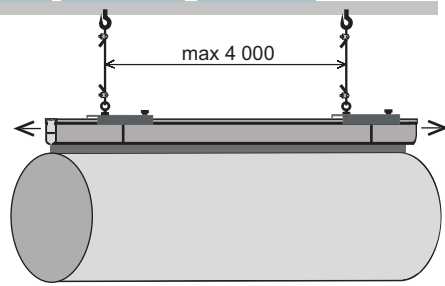

5EI see details F, R

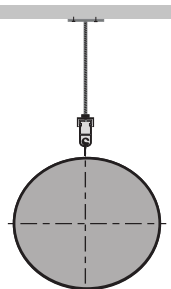
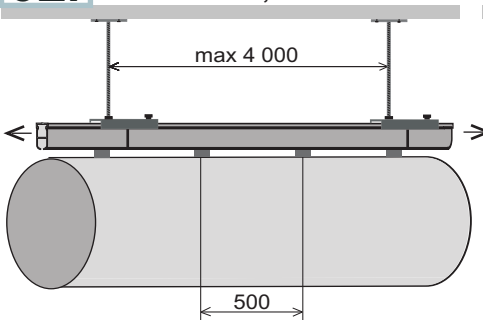

5AEI see details F, G, R

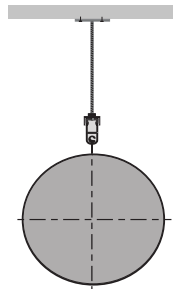
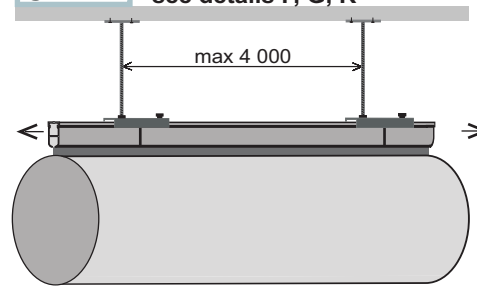

6 6D 6F see details G, E, F, K

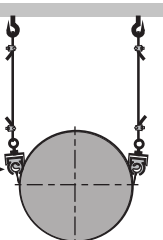
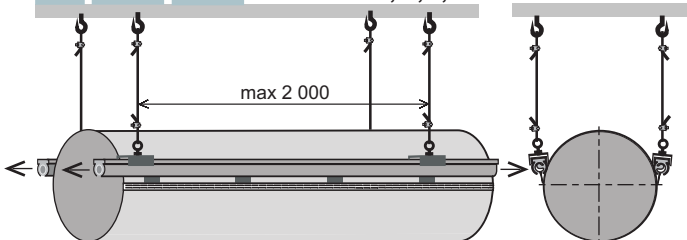

6E see details G, E, F

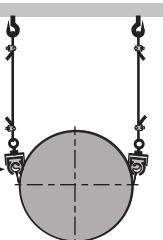
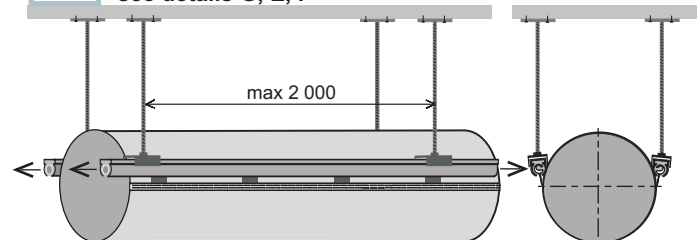

5A 5AD 5AF see details G, E, F, K

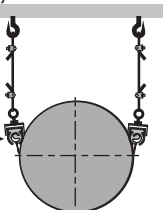
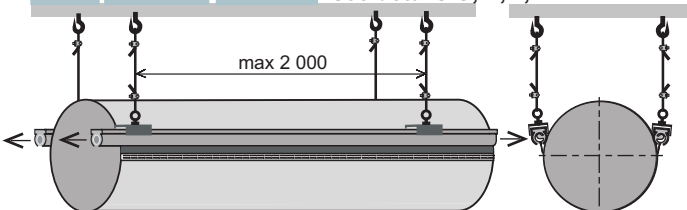

5AE see details G, E, F

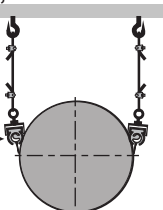
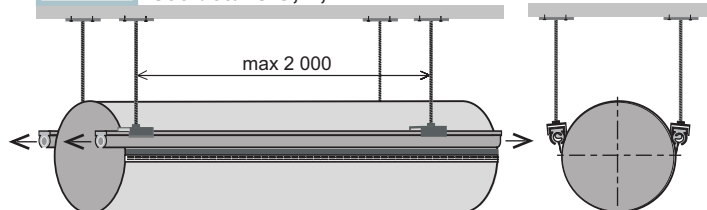

6G see details F, M

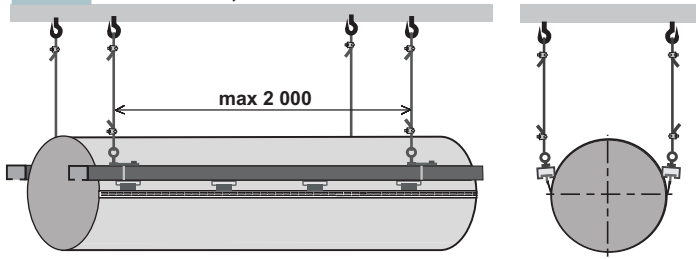

6EG see details F, M

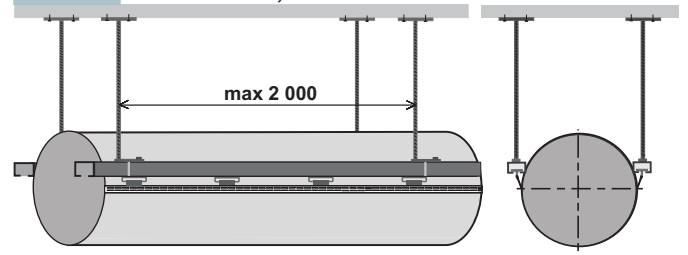

6I 6DI 6FI see details G, K, R

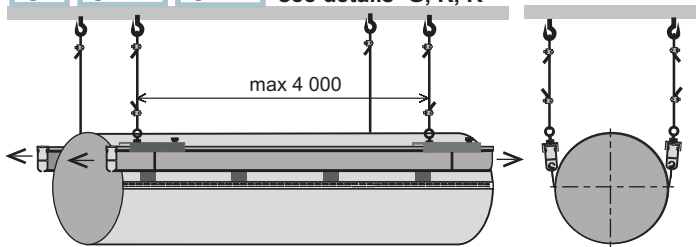

6AI 6ADI 6AFI see details G, K, R

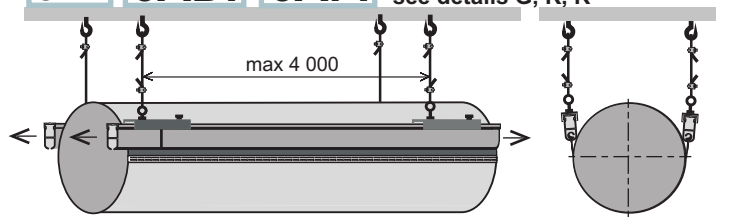

6EI see details F, G, R

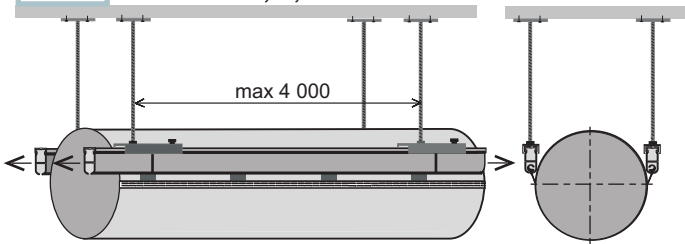

6AEI see details F, G, R

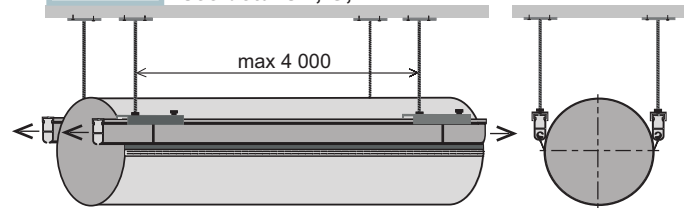

7 7D 7F see detail A

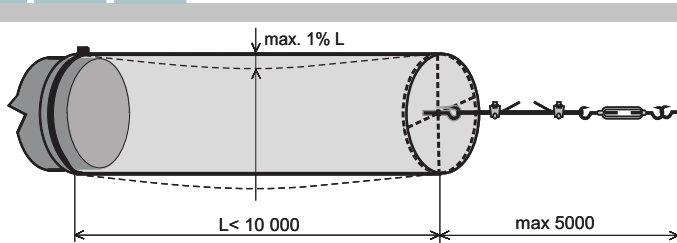

7H see detail Q

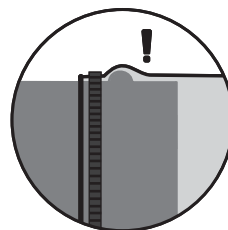
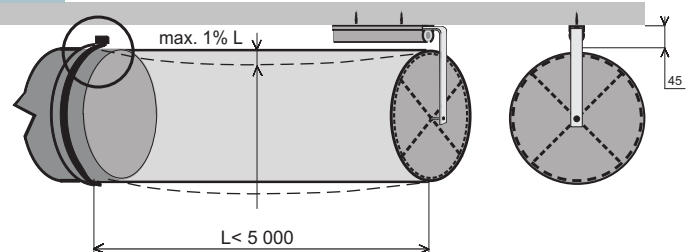

detail

COMBINATIONS

1. COMBINATION OF SINGLE AND DOUBLE INSTALLATION:

2+1, 2D+1D, 2F+1F, 4+3, 4B+3B, 4C+3C, 4G+3G,
6+5, 6A+5A, 6AD+5AD, 6AE+5AE, 6AF+5AF, 6D+5D, 6E+5E, 6EG+5EG, 6F+5F, 6G+5G

Examples:

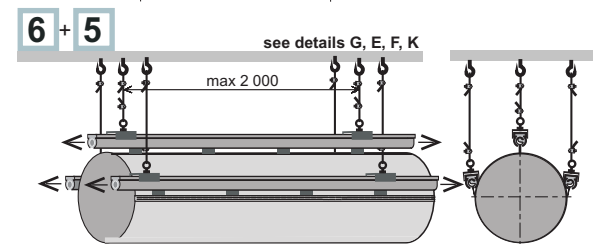
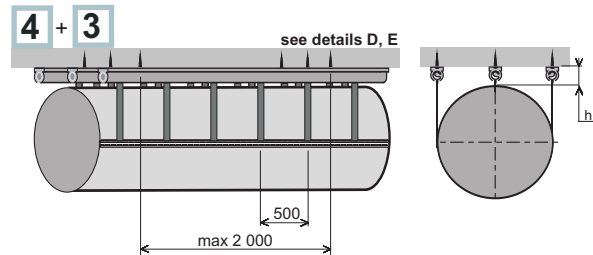
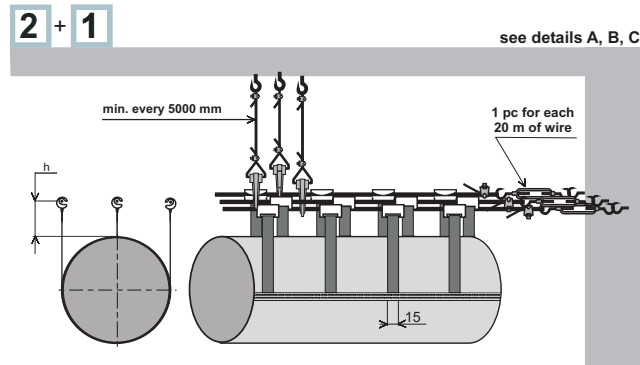

2. ADDITIONAL TENSIONING TYRE:

ORDINARY INSTALLATION +7

Examples:

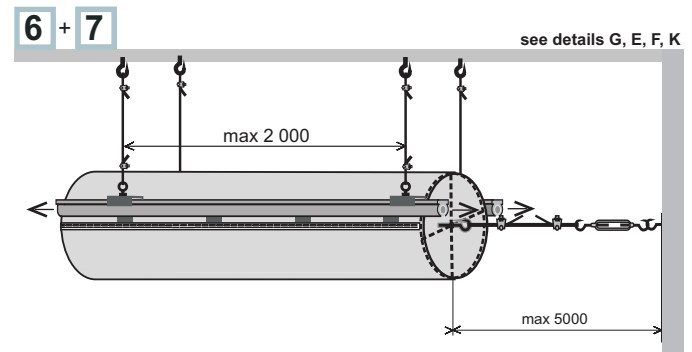
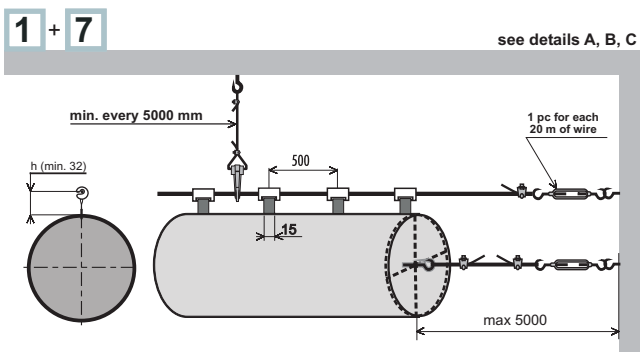

COMBINATION OF INSTALLATION + 7H:

3+7H, 3A+7H, 3AC+7H, 3C+7H, 4+7H, 4B+7H, 4C+7H, 4G+7H, 8+7H, 8A+7H, 8B+7H, 8C+7H,
8AB+7H, 8AC+7H, 8G+7H

Příklady:

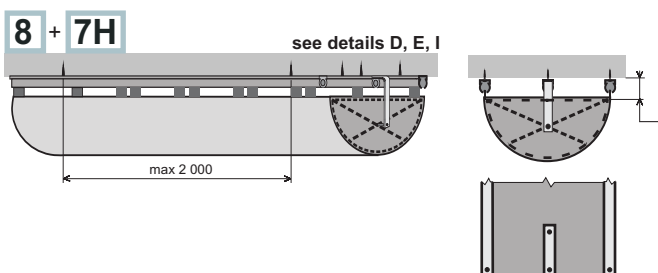
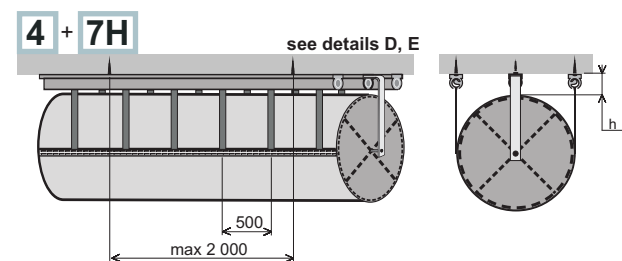
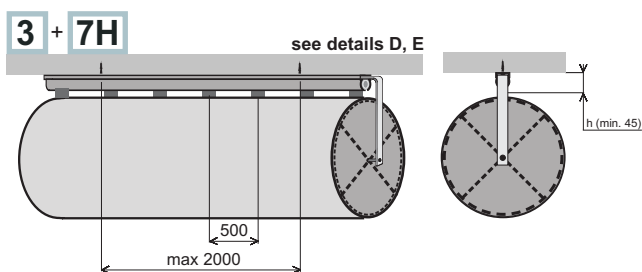

8 see details D, E, I

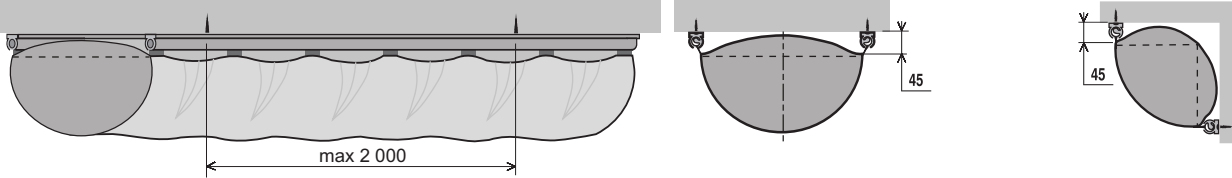

8A see details D, E, I

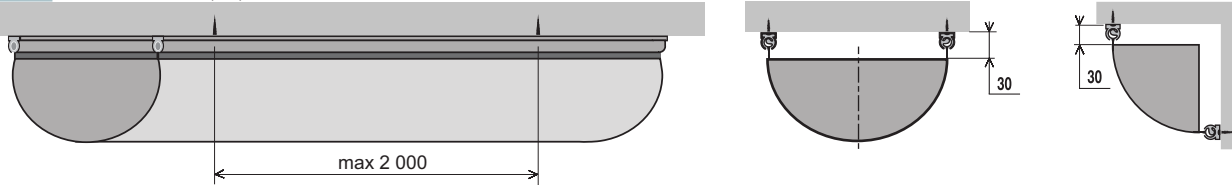

8B see detail H

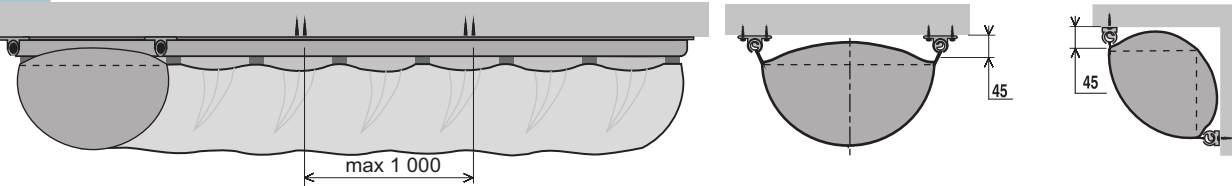

8AB see detail H

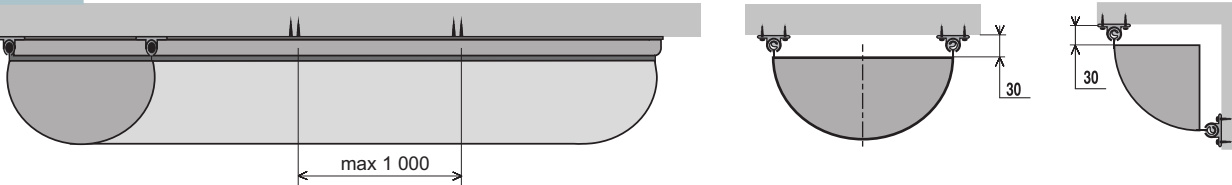

8AC see details J, E

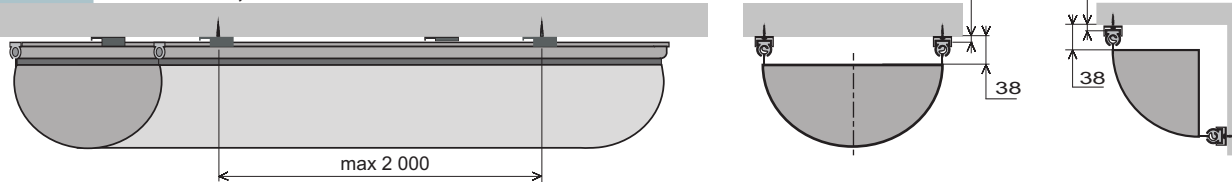

8C see details J, E

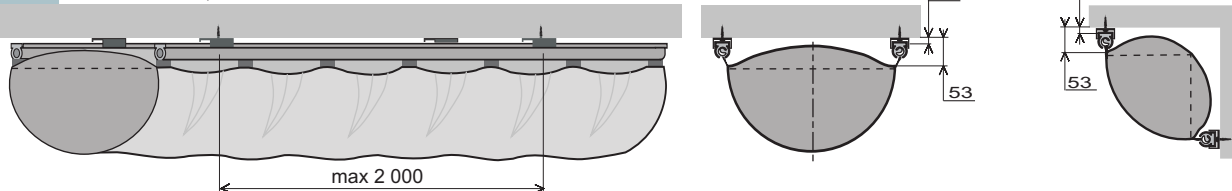

8G see details L, N

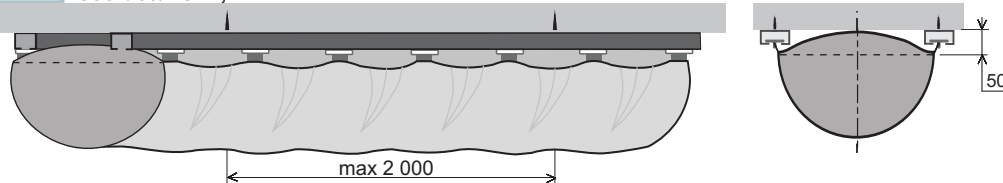

DETAILS

A

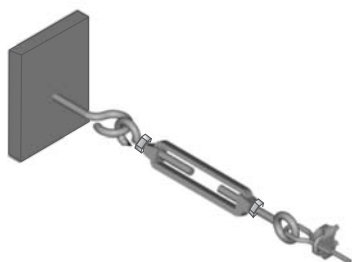

B



C



D

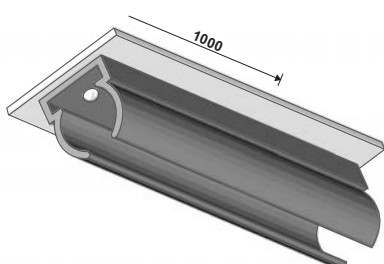

E

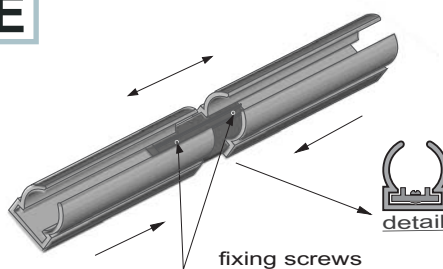

F

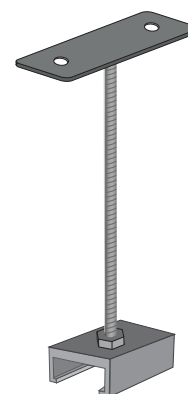

G



H

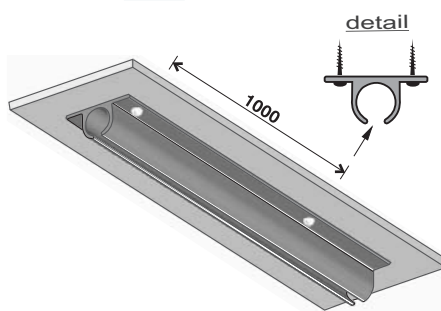

I

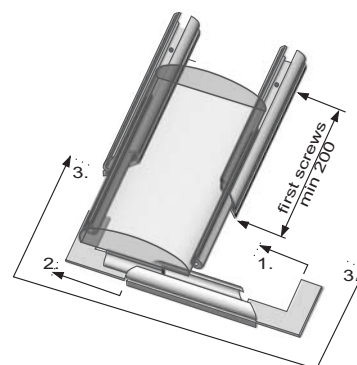

J

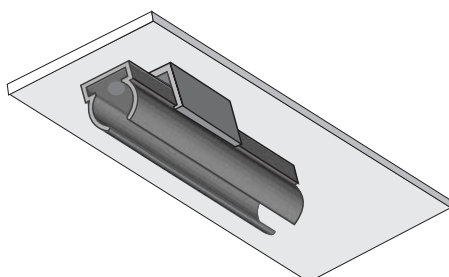

K



L

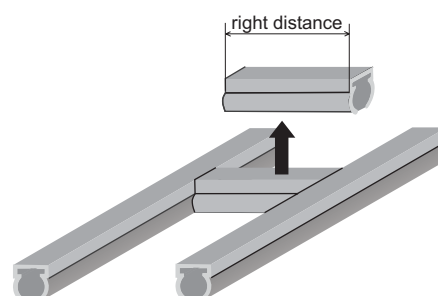

M

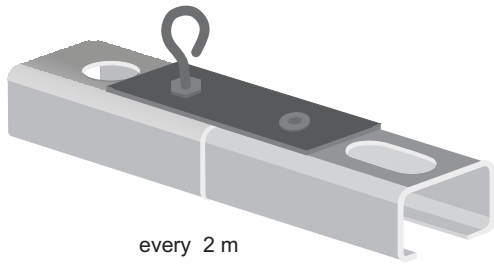

N

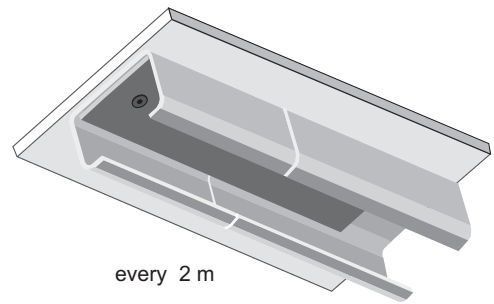

O

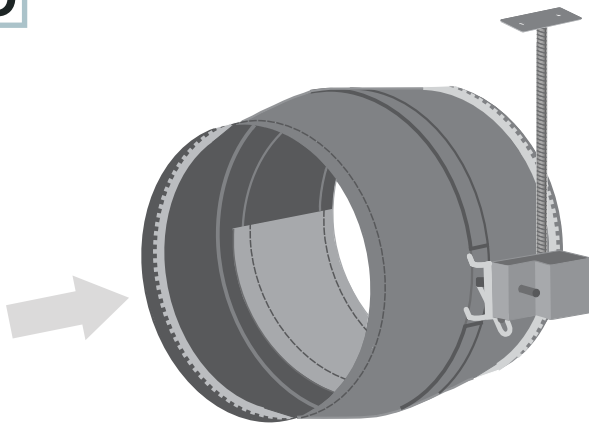

P

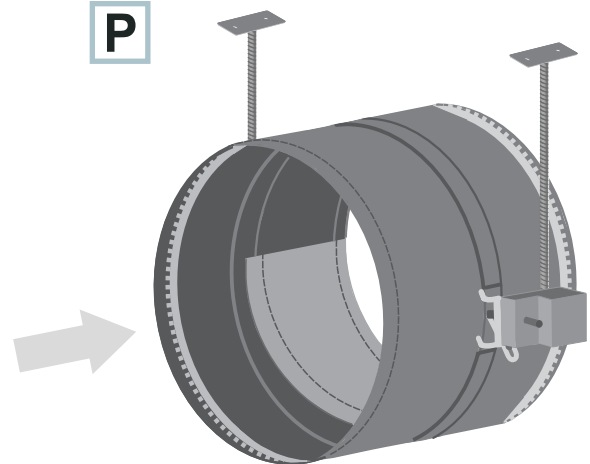

Q

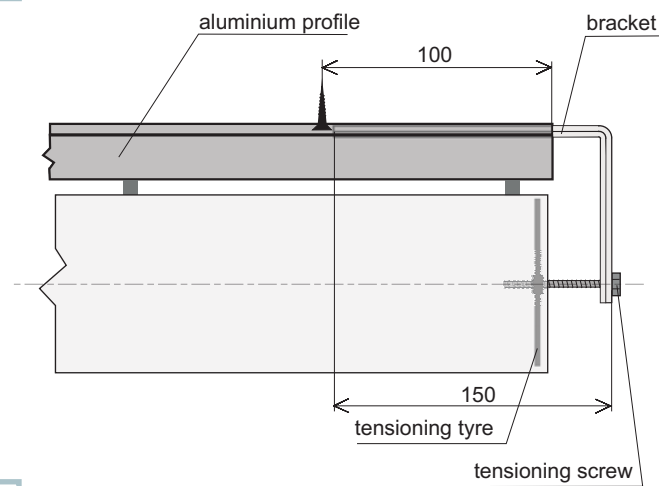

R

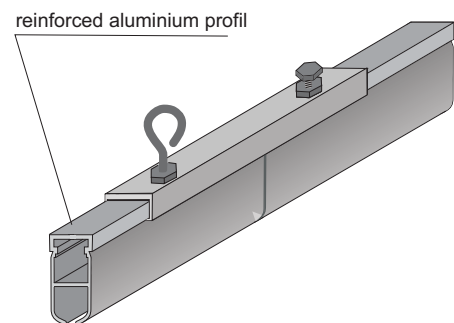

S

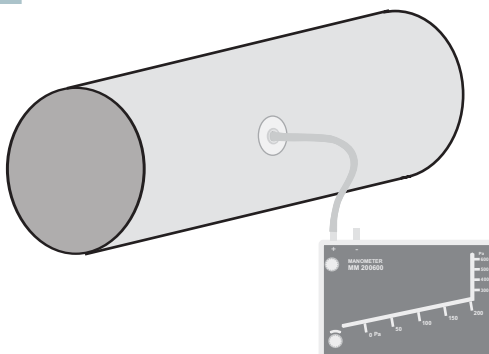

ASSEMBLY

The diffusers (having been washed) must be kept dry and wrapped in a clean dry place till the installation. After unwrapping, the diffusers cannot come into contact with dirt. The mechanics must have their hands washed. The diffusers should be installed according to the pictures 1 - 8 G. All the supply part of the air duct must be absolutely clean before the diffuser is inflated for the first time. Do not start up the ventilator until the whole duct is installed. There is a danger that the fabric could be damaged.

Read through all the under-mentioned instructions and think over your concrete conditions. These instructions and the drawing of the concrete installation are parts of every shipment. Look through the drawing and compare it to the marked pictures. If there are differences between the drawings, the drawing of the concrete installation is to be used.

The diffusers are divided into several sections connected by zippers. Each section is marked with a number, which is given in the technical drawing attached to the supply. This number corresponds to the marking on the washing labels sewn in by the zippers. The form of the number is: position - section number / total number of sections. E.g.: 02 - 03 / 05 means 2nd position, its 3rd section from among 5.

RECOMMENDED TECHNIQUE OF INSTALLATION

1 Prepare the mounting material which is not included in the supply:

wall plugs, hooks and screws. The list of the supplied mounting material is attached.

2 Install the diffusers according to the pictures 1 - 8C and according to the drawing of your concrete installation which is attached to the supply.

The technique of your installation is coloured.

3 Other mounting instructions:

- If a special make is not required the standard distance between the upper right side of the duct and the wire is 32 mm.
- for installations 2,4,6,8: horizontal distance between stranded wires or profiles corresponds to a diffuser size.
- for installations 1,2,5,6: arrange hangers to required lengths and install them first (there is one wire hanger per every min. 5 m length of wire or every 2 m length of profile).
- for installations 1,2: install turn-buckles in completely open position.
- for installations 5,6: It is important to tighten the thread bar properly against the profile and fix it with a safety nut.(see details F, G).
- textile connecting strips are fixated in the tags sewn on diffuser connecting pieces.

4 Mounting of diffusers to metal conduit or evaporator:

Circular section

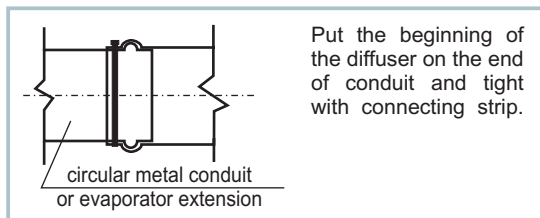

Half-round section

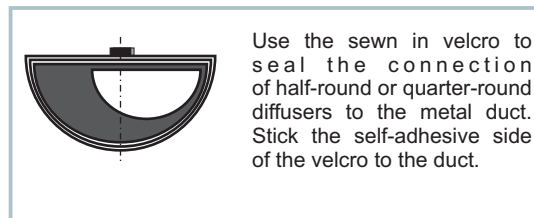

Square section

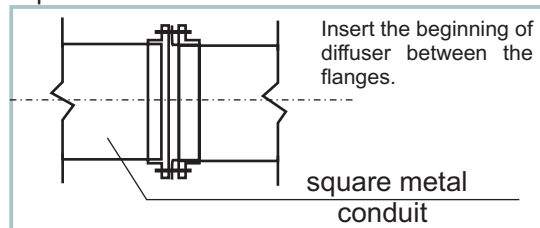

To the evaporator side

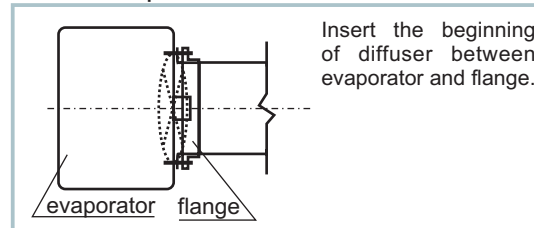

5 Mounting of Membrane diffusers:

- when you have attached the beginning of the diffuser according to point 4, zip the flap of the membrane on to the beginning.
- anchor the flap by means of a threaded rod (diameter up to 630 incl. - one threaded rod, diameter over 630 - two rods) see detail O, P on page 32.
- install the subsequent part of the diffuser on a wire or into a profile and zip it on to the flap - the membrane at first, the diffuser afterwards.

Electrical wiring: Wiring diagrams

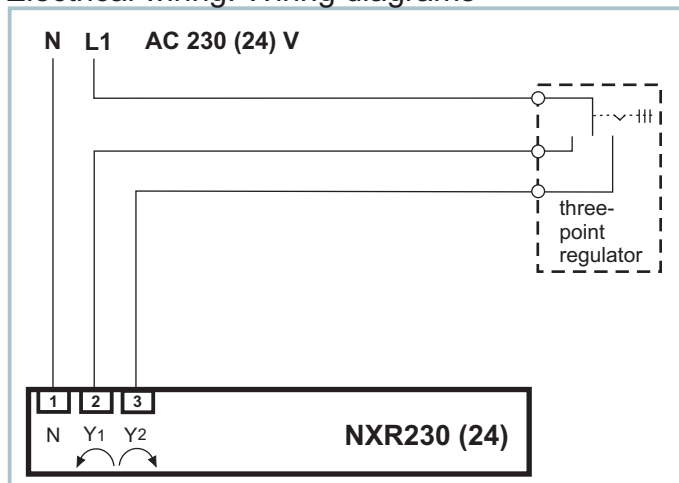

Minimize the frequency of position transitions by means of a proper heat supply control. Facilitate the transition only when certain temperature has been reached. Determine the proper hysteresis (e.g. 2 - 3 °C) according to local conditions.

- When the servomotor has been plugged in, the flap turns to either of the starting positions.
- The position of the flap can be altered manually after the rotary knob on the case has been turned to the proper position.
- The membrane position can be watched by means of a joystick.
- 0° and 180° are working positions of a servo motor. A halt position differing from the working positions by $\pm 5^\circ$ does not affect the functionality.

! The producer does not warrant for undamaged state of the membrane if the flap is turned behind the border positions !

6 Assembly of a tensioner:

Installation 7: Connect the diffuser according to point 4. Anchor the wire with the tensioner on a sturdy structure opposite the blanking in the direction of the diffuser axis. Pull the other end of the wire through to the tensioning tyre sewn in the blanking, adjust the length of the wire. Tightening of the tensioner effects the proper strain.

Installation H: Attach the aluminium profile to the ceiling or a structure according to detail Q. Put the bracket with the tensioning screw into the profile. Attach it to the tensioning tyre sewn in. Tightening of the tensioner effects the proper strain.

7 NHE fabric:

- The fabric is fragile and can crack at folds. Prevent the folded fabric from a load and formation of sharp-edged folds!
- The brunt of air the starting ventilator brings about can damage the fabric. Provide for gradual starting up of the ventilator.

8 Smell from diffusers:

- The openings in the fabric are burnt by lasers. A smell of burning and smoke exhale during the burning process.
- Residue of smells can exhale also from the finished products for a short time after their installation. In such a case, an intensive fresh-air blowing is recommended for two weeks time. All the smells vanish within that time. Health-innoxiousness was demonstrated by chemical analysis.

MAINTENANCE

All our diffusers are made of high-quality resistant materials without a natural fibre admixture. The used material is specified when your order is technically processed.

The diffusers made of permeable fabric can be washed in a common industrial washing machine.

The diffusers made of the fabrics NHI, NHE and NMD can be washed manually only. Remove the tyres or the blind end reinforcements from the diffuser equipped with these tough parts before washing them.

The process of washing:











Observe the set maintenance symbols of the particular product thoroughly before you wash it.

The washing labels are sewn in in the diffusers by the zips.

We recommend:

1. Wash the diffusers with common detergents (dosing according to the directions for use), the effect of washing is enhanced if the diffuser is turned inside out. We advise you to repeat the washing up to four times acc. to level of contamination. A special detergent (we will recommend one by request according to the particular dirt) should be used if the fabric is badly soiled.
2. Use a disinfectant only if it is essential according to the local service instructions. The chemical composition of the disinfectant must not harm the diffuser fabric (see maintenance symbols). Observe the producer's dosing instructions.
3. Rinse the diffusers in clean water.
4. Spin-dry the diffusers gently, install them and finish drying by the air flow from the ventilator.

Symbols key:

	max. temperature for washing 40°C normal mechanical action normal rinsing normal separating
	gentle washing in a washing machine, maximum temperature 40 °C, gentle mechanical action, rinsing in water cooling down, gentle spin-driing
	washing only by hands product must not be washed in washing machine max. temperature 40°C cautious handling
	product must not be whitened with detergents disengaged chlorine
	dry in a drum-drying machine use lower temperature of drying
	product can't be dried in a drum-drying
	ironing within of max. temperature of ironing surface 110°C, cautious with steam ironing
	product must not be ironned steaming is inadmissible
	product must not be dry cleaned the stains must not be removed by organic solvents
	product can be dry cleaned with tetrachlorethen, monofluortrichlormethan and all solvents mentioned with symbol F usual cleaning progresses are without any limits